

RESULTS OF THE WORK OF THE NEWLY CONSTRUCTED MACHINE FOR PLANT PROTECTION

R. KUKUTANOV¹, Z. DAVCEV² and I. CANEV²

¹ *University of Stip, Agricultural Faculty, Stip, R. Macedonia*

² *University of Skopje, Faculty of Agricultural Sciences and Food, 1000 Skopje, R. Macedonia*

Abstract

KUKUTANOV, Risto, Zivko DAVCEV and Ile CANEV, 2011. Results of the work of the newly constructed machine for plant protection. *Bulg. J. Agric. Sci.*, 17: 132-137

This study describes the prototype construction of a composite machine which can perform application of different types of pesticides, and cut with pneumatic clippers. These are the preliminary results of the development of a newly-constructed machine. The idea of the machine was implemented as a construction idea. The improvement of the machine is still ongoing process and the goal is to improve the usage of the tractor aggregation, and to come up with a simple and cheap construction which will bring quality to its work.

Key words: Prototype, construction, protection

Introduction

Protection as agro-technical measure, much depends on the time of application, choosing the appropriate plant protection product, but also on the manner of application. The effects of certain types of pesticides depend on the manner of their application, and size and number of drops.

The problem of applying the active substance from certain quantity and finely preparation of the plant protection product is a priority and goal of every professional in this practice. From the overall amount of expenses, most of them are going to the maintenance and frequent failures during its execution. Today's machines for application are more precise in the process of application, but also more complicated, which creates the problem

of their high cost price, but also to increase the planned and unplanned costs during the year. The need for setting up a simple structure and a machine that will perform more processes imposes new tendency of modern agricultural production, which generally joins the three parameters: quality of application, low purchase price and easier way of maintenance.

The purpose of this two-year active research work refers to the idea to construct prototype machine for cutting and application that will perform these processes quality and cost effective.

From the initial phase of construction of this machine, until their release in active function, many changes and additional upgrading of the component (positions) in order to be functional, practical and easy to operate and maintain.

Of course the goal was to construct machine for application application, that will not come into question the quality of the application on different cultures.

Material and Method

Brief description of construction prototipnata

The construction of the machine its is very simple and represents a major component is the slot, frame chassis which is mounted tank if needed and depending on the size, and of course depending on the surface of the crop. The tank can be metal or plastic. Due to simplicity of construction and availability in the prows of building the machine, we put a metal tank. The framework sets sprinkling valves and which has the ability to perform any kind of regulation, depending on the needs of application and order of application.

Figure 1 presents a scheme display of the pro-

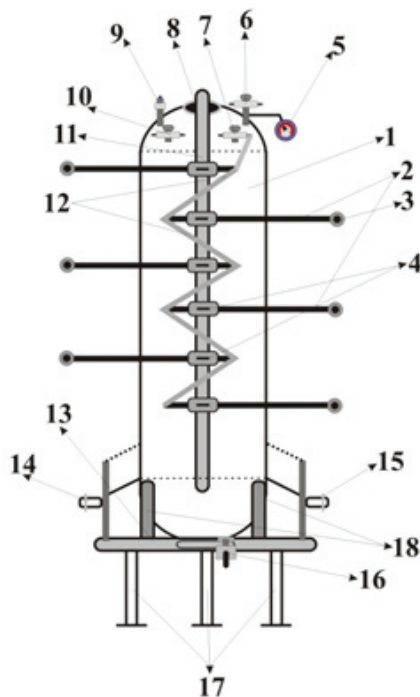

Fig. 1. Scheme of construction of prototype machine

totype machine with all its parts and the parts for regulation. In the scheme you can see that it is carried machine and that you can install from 2 to 15 sprinklers's, depending on the type of culture. Also, you can set two separate sprinklers that can perform manuall application if necessary. During the work you can control the working pressure, which is controlled by manometer. The scheme shows that the prototype machine don't have pump for creating the pressure which is making this machine cheaper , easier to maintain and also taking in consideration this two parameters will certainly get more cost effective application.

Methodology and working techniques

The methodology of work was adjusted in order to investigate the functionality of this type of machine to check the functionality of all positions, the manner of operation, the manner of regulation and their compliance, and type of different quality application boards (boards of sprinklers). Special attention was dedicated to the regulation and quality of the application, having in mind the purpose of the machine for application on different types of cultures, but in different developmental stages. The second option, which was covered by this study, was the type of tiles used for the application. One of the goals that are set by DSMSTS masshins CS spliks-cijs is to determine whether the type of quality and type of tiles will affect the quality of



Fig. 2. Mode of regulation on valve for application of plants

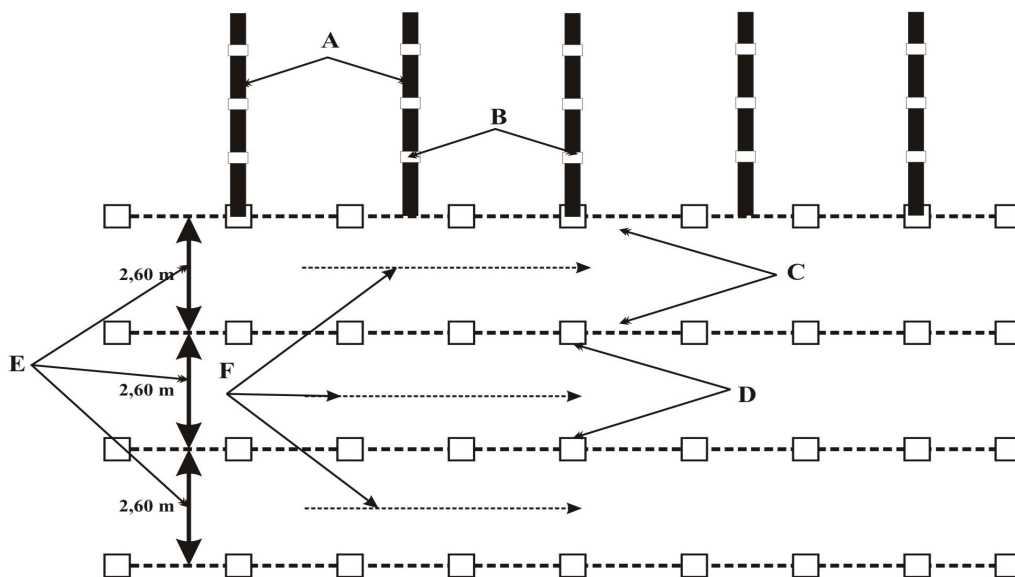

Fig. 3. Scheme how to locate test for examination of quality application

applications at the same regulation of the exploitation characteristics of aggregates.

In terms of regulation, during the two-year work was noticed that the machine can be adjusted from 1 to 12 bar working pressure in both variants, carried out the valve for regulation. During the tests we worked with different pressures, which showed that all its constituent parts for this purpose are mutually agreed and regulation is simple and can be accurately performed for each type of agricultural crops. The number of sprinklers are regulated during the probation period we worked with one of the frame with the possibility of usage of ten sprinklers, and it was noted that all work under the same pressure Davcev (2008) (Figure 2).

The construction gives opportunity for the different types of sprinklers, as appropriate, different types of the jet, which can satisfy all the needs of the agricultural culture and its developmental stages. This gives the opportunity to put different pressure sprayers, but also to create different jet of the plant protection material. For two-year trial we performed many tests and found that it is possible any kind of regulation by number and types of sprinkler systems as needed. The quality of the

application is one of the most important parameters for examining the application of machinery, and it was a priority in the two-year testing.

Scheme in Figure 3 introduces the experiment to determine the quality of the application, which will allow recording the number and size of droplets of varying height in shpalir system of growing vines and use of metal and ceramic tiles.

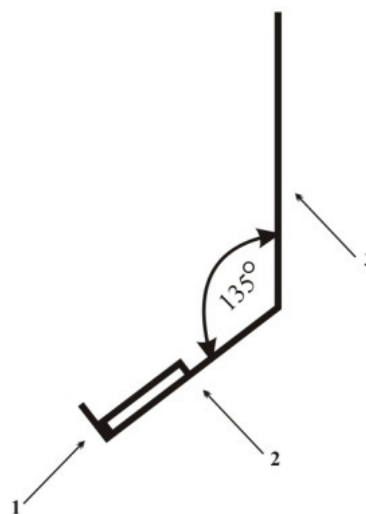

Fig. 4. Cardboard saddles

As factors are taken into account the different amount of available testers and distance in order to determine the quality of the application according to range, size and number of drops in the application in two variants. The number and size of the drops have been recorded so-called paraffin method. For this purpose, we used special paper ballots with the microscopic size of the object glass, which were once used the same method of examination. Then we placed the cardboard carriers (Figure 4) consisting of 3 parts at an angle of 135° in order to accept the drops ideally. In making the cardboard carriers we need to pay attention to the relationship between 2 and 3 part to be 2:1, leading trellis in order to set properly. Setting the petals of a trellis is the leading height of 50 cm, 100 cm and 150 cm, calculated from the surface of the soil. We set up five central trellis with 3 experimental papers, and distance ie distance of the reach of sprinkler not take distance between the threes (three repetitions) in order to see the scope, size and number of drops, and in both types of tiles for application. After we made field recordings switched to laborator tests or analysis of leaves under the electron microscope, 33 time

enlargement in order to determine the number of drops and their size in certain variants.

Results and Discussion

The obtained results indicated in Table 1 are made after five repetitions with a standard sprayer (one hole in the plate of metal and porcelain type) of shpalir system of cultivation. We worked with a working pressure of 5.5 bar and an average operating speed of 7.2 kilometers per hour Davcev (2005).

From the table it can be concluded that the five repetitions were obtained satisfactory results, the number and size of the drops from 1 to 100 micrometers takes somewhere around 90% of the total number of drops per square centimeter, with application plate made of metal and tile made from porcelain. During the application we performed a very good mixture of air mass and drops back in sprayers (for both types), as well the finely of the solution came to the solution when exiting the sprinkler befits a homogeneous mixture of the solution. Befits an additional finely of the solution and its distribution to the green table, which enables

Table 1
Review of overall number of droop with same standard nozzle

Number of test	Number of droop per definite size in micrometers on cm ²										Total with metal plate	Total with porcelain plate
	sprayer with metal plate	sprayer with porcelain plate	sprayer with metal plate	sprayer with porcelain plate	sprayer with metal plate	sprayer with porcelain plate	sprayer with metal plate	sprayer with porcelain plate	sprayer with metal plate	sprayer with porcelain plate		
	1-50	1-50	50-100	50-100	100-200	100-200	200-300	200-300	300-500	300-500		
I	218	166	76	64	22	17	4	2	0	0	320	249
II	240	184	70	58	26	21	4	1	0	0	340	264
III	231	144	68	53	16	14	6	3	0	0	321	214
IV	241	158	62	60	20	16	3	3	0	0	326	237
V	236	135	66	49	18	12	3	2	0	0	323	198

the solution to be applied to the green table in the form of tiny dew Marx et al.(2007).

It is noted from Table 1, where we fully satisfied all the basic criteria in the application, because the active substance of preparation is applied evenly on the green parts and nowhere noted case of a merger or swelling of the droplets of the solution. The work is noted that a large number of droplets reach the next row, and that these measurements are recorded. By recording the drops we recorded that the drops have a circular form, with what the green parts of the plant is correctly applied to the active substance of preparation, as the outer and the inner of the application of two ways, in the bouth both types of application tiles. The presence of air power allowed good penetration of the drops in the inner part, which in some vines and fruit crops is a necessity to carry out a proper application. Obtaining a quality program that provides course and off the sprayer, which can be opened if needed to play more or less flow of solution depending on the culture and depending on the application in order. Such regulation allows easier adjustment of the flow of solution and air mass depending on the needs of the application, which is monitored during the year of vegetation. During the test trials there was no need for the ratio of the solution and air power, which of these variants will give best results and remained an imperative task to continue studies in the following years of vegetation Carter (1985).

The advantage of this machine is in the regulation of air mass, which can strengthen or weaken depending on the distance of the vegetative mass. Such regulation allows you to perform application of high altitude plants with up to 8 m, without accessories for the sprinklers. Certainly this examination of newly constructed machine will continue, with the improvement that will occur as a result of the realization of the needs of modern application.

Conclusions

From the overall the following conclusions could be made:

Satisfactory results were obtained in the five repetitions, with the number and size of droplets from 1 to 100 micrometers occupies around 90% of the total number of drops in a square centimeter, with application and plate made of metal and tile made from porcelain; all the basic criteria in the application are fully satisfied, because the active substance of preparation is applied evenly to the green parts and nowhere was noted the case of connection drops or swelling of the solution;

The advantage of this machine is in the regulation of air mass, which may reinforce or weaken depending on the distance of the vegetative mass that allows you to perform application of high altitude plants with up to 8 m, without additives on the sprayers.

References

- Brcic, J.**, 2001. Handbook for Working with Sprayers and Air Assistance Sprayers. No 1-2: 659 pp. (Sr).
- Carter, M. V.**, 1985. Evaluation of a Manual Spraying Secateur for Protecting Trees and Grapevines against Wound-Invasive Pathogens. *Australasian Plant Pathology*. **14** (2): 43 – 44.
- Carter, M. V.**, 1985. Evaluation of a Manual Spraying Secateur for Protecting Trees and Grapevines against Wound-Invasive Pathogens. *Australasian Plant Pathology*. **14** (2): 43 – 44.
- Davcev, Z., R. Kukutanov, I. Canev and R. Nakova**, 2008. Handbook for Proper Use of Equipment and Machinery and Applications of Plant Protection Chemicals (Pesticides). Skopje, 143 pp. (Sr).
- Davcev, Z.**, 2005. Exploitations of Agricultural Techniques. Regular textbook, University “Ss. Cyril and Methodius” – Skopje, Faculty of Agricultural Sciences and Food, Skopje. (Sr).

- Davcev, Z.**, 2003. Fundamentals of Agricultural Equipment. Regular textbook, University “Ss. Cyril and Methodius” – Skopje, Faculty of Agricultural Sciences and Food, Skopje. (Sr).
- Kukutanov, R. and I. Canev**, 2010. Mechanizations in Agricultural Production. Agricultural Faculty, University in Shtip. (Sr).
- Kukutanov, R. and I. Canev**, 2009. Mechanizations in Vegetables and Flowers Production. Agricultural Faculty, University in Shtip. (Sr).
- Marx, S., A. Paul, A. Koler and G. Hüttl**, 2007. Cold spraying: Innovative layers for new applications. *J. of Thermal Spray Technology*, **15** (2): 177-183.
- Shtefan, K.**, 1991. News in the technique of spraying of weeds in sugar beet with the results from practice. *Journal Agrotehničar*, No. 2/3 Zagreb. (Sr).

Received September, 2, 2010; accepted for printing January, 12, 2011.

Editorial Note:

In: No 6 / Volume 6 / 2010 the article: “Content of Row Proteins in Oat Depending on the Growing System in Strumical Region, Macedonia”

Authors: D. Spasova, S. Mitrev, A. Stoilova, D. Spasov and R. Kukutanov