

## DESIGN AND CONSTRUCTION OF ROTARY POTATO GRADER. (PART I)

R. FARHADI<sup>1</sup>, N. SAKENIAN<sup>2</sup> and P. AZIZI<sup>1</sup>

<sup>1</sup> *Department Of Agricultural Machinery Engineering, Shahrekord University, Iran*

<sup>2</sup> *Islamic Azad University, Engineering Dept, Shahrekord Branch, P. O. Box 166 Shahrekord, Iran*

### Abstract

FARHADI, R., N. SAKENIAN and P. AZIZI, 2012. Design and construction of rotary potato grader. (Part I). *Bulg. J. Agric. Sci.*, 18: 304-314

One of the main potato usages is seed consumptions. According to researches, seed potatoes should position on the 50-80 g Mass range. Two hundred potato samples were selected from the conventional varieties (Morfana and Agria) in Iran. Dimension and mass was measured and regression equations were calculated at Excel software. These equations solution at Matlab software eventuated numbers of 36.36 and 42.68 mm corresponding with 50-80 g for Morfana, also 31.66 and 29.55 mm for Agria. These numbers indicated the situation of separator plates on the system. A new mechanism was suggested for gradation included a helix with variable distance. Effective parameters on the gradation helix were identified and attempts were done for their suitable selection. Hence, computer model prepared from the system. Then, coefficient of friction between polyethylene pipe and potato was obtained respectively 0.5583 and 0.4531 for Morfana and Agria using inclined plane at ten repeats. Finally, effective parameters on the system were chosen according to software analyses, conditions and limitations. Some experiments were done after set construction for achieving maximum gradation precision with optimal place determination of separator plates. Experiments results were numbers of 35 and 45 mm for Morfana, 28 and 33 mm for Agria. Theoretical and actual product transfer volumes were acquired 4.36 and 3 tons/hour. System required torque and power were 75 N.m and 71 Watt.

*Key words:* gradation, potato, precision, rotary helix, mass range

*Abbreviations:*  $\omega$  : Rotational speed, V: Linear speed, t: Time, T: Alternation time, x, y and z: Distance in three dimensions,  $\theta, \alpha$ : Angle, l: Pitch length, L: Total length, r, R: Radius, A: Area,  $\bar{y}$  : Centroid, a: Distance, s: Arc length,  $v_{T,T}$ : Transferred product volume at alternation time,  $v_{T,1}$  Or  $\dot{v}_T$  : Transferred product volume at time unit (1s),  $\dot{M}_T$  : Theoretical transferred mass at time unit (1s),  $\dot{M}_A$  : Actual transferred mass at time unit (1s), K, c: Constant,  $Q = \dot{M}_I$  : Input transferred mass at time unit (1s), P: Precision, g: Acceleration due to gravity, b: Total distance in helix, n: Number of pipe, d, D: Diameter,  $\rho$ : Density of material

### Introduction

Potato consumption such as seed, presenting to bazaar for selling, starch preparation, feed of do-

mesticated animals and production as chips, peel, conserve and so on, needs special conditions and it should be prepared before delivery to that particular application. The objective of gradation is prep-

aration of this background and product uniformity and coordination for each usage. Advantage of accreting such conditions is control simplicity of production process, increase of efficiency, system mechanization and desirable design performance and so on.

This question is propounded considering ability of potato gradation based on different characteristics like weight, dimensions, density and volume, that which is the gradation criterion? Whether are graded uniformly other product characteristics with selection of each mentioned items? For response, it should refer to gradation goal. For example, length, density, shape and size respectively are noteworthy for chips preparation, potato drying and selling at market. Seed preparation is important and essential than other various usages and it is based on mass. Many researches have been done in this field.

Iritani et al. (1984) found whatever seed piece was bigger, the yield became greater but utility of seeds above 2.5 ounces reduced.

Bohl et al. (1995) presented seed suitable mass for cutting about 3-10 ounces and cut pieces for planting 1.5-2.5 ounces.

Johnson (1997) reported seed ideal mass about 1.5-2 ounces.

Therefore mass was based for gradation as criteria regarding recommendations and importance of potato seed preparation.

Different methods have been applied for gradation and developed for various zones and needs since many years ago. Now, history and done works are stated briefly in the grader machines field.

Jenkins (1920) presented a machine for grading potato at United States patent office. It included meshy plate with variable size. Products were graded with passage of plate suitable hole and dropping in the prepared boxes under the system.

Jacob et al. (1965) exhibited an automatic gradation machine of agricultural products based on color and Delayed light emission (DLE). DLE ex-

presses if light is flashed to normal potato (yellow) and undesirable (green and yellow) then the light source parts, they emit absorbed light but emission intensity is stronger at green potatoes. Thus, a detector and deflector can prepare separation conditions.

Shyam et al. (1990) designed and made a potato grader machine with oscillating screen and operation of 250 kg/ hour. Gradation precision was reported 80-90% using a person for tendance and avoiding screens obstruction. Damages were measured 2% while operation. Machine required 10-14 workers.

Noordam et al. (2000) presented a high-speed machine vision system for quality inspection and grading of potatoes. The vision system could grade potatoes on size, shape and external defects such as greening, mechanical damages, silver scab, common scab, cracks and growth cracks. System could transfer products with the capacity of 12 tons/hour and its precision was 90%.

Butler et al. (2005) exhibited a potato grader machine for small-scale farms. Ten conical cylinders performed gradation work. Machine precision was respectively with zero and  $\pm 2$  mm tolerance under different conditions 75-80% and 87-91%. Operation was reported 2.3-3.8 tons/hour. Severe scuffing occurred to 0.1–0.2% of tubers and slight scuffing to  $\leq 40\%$  of them that it was the main imperfection of machine.

Ghanbarian et al. (2010) reported a potato grader system with drum made of Capron net as gradation surface with square cells. The cells of net had dimensions of 35×35mm and 45×45mm. Machine could grade products in three sizes: small (below 50 g), medium (50 to 80 g) and large (above 80 g). Its gradation accuracy was about 74% and mechanical damages of potatoes were 5.5%.

Each machines and mechanisms had advantage and defect. For example, optical and machine vision graders were not economical for some users because of heavy cost. Some had much construc-

tion cost due to complex mechanism and at some, required workers was high and so on.

The presentation and investigation objectives of this design are summarized at appendix:

- Because the considered mechanism at this research is new, its operation and performance should study until, comparison possibility is provided with available others systems.
- Design simplicity, inexpensive and available primary materials for construction is vantages of system.
- System can transfer and grade products at inclined state.
- In addition, this feasibility exists to connect system to rotary potato harvesters and products are graded in the farm.

## Materials and Methods

### Acquaintance with gradation mechanism

Gradation mechanism is a helix. When the helix rotates, fed materials jut and go over.

Helix of Figure 1 could grade potatoes considering pipes variable distances from beginning to end.

### Effective parameters recognition at helix

As regards work base was rotary helix, finding the 3D helix equation at space was first step.

### Helix equation

Particle motion path was followed for production of the helix with constant linear speed of  $v_0$

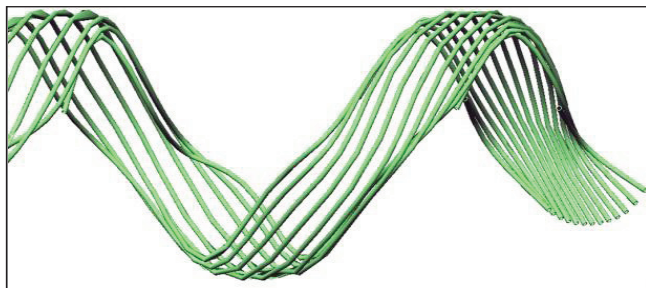

Figure1. Flexible pipes with variable distances.

while rotates around an axis with the distance of R at rotational velocity of  $\omega_0$ . Figure 2 shows the corresponding path.

Appendix equations can be written for helix:

$$z = z_0 + v_0 t \quad \text{and} \quad \theta = \omega_0 t + \theta_0 \quad (1)$$

where z: meted distance at z-axis direction and t: time. With some variation

$$\frac{z - z_0}{v_0} = t = \frac{\theta - \theta_0}{\omega_0} \Rightarrow z = \frac{v_0}{\omega_0} (\theta - \theta_0) + z_0 \quad (2)$$

Now, the relationship is written with pitch length instead of  $\frac{v_0}{\omega_0}$ .  $t'$  is the time that particle rotates one revolution, then  $2\pi = \omega_0 t'$  and  $l = v_0 t'$  (3). Here, l is pitch length. From last equations results:

$$\frac{l}{v_0} = t' = \frac{2\pi}{\omega_0} \Rightarrow \frac{v_0}{\omega_0} = \frac{l}{2\pi} \quad (4).$$

Finally, the helix equation transforms as follows:

$$z = \frac{l}{2\pi} (\theta - \theta_0) + z_0 \quad (5)$$

It can be written from Figure 2, for x and y:

$$\begin{cases} x = R \cos \theta \\ y = R \sin \theta \end{cases} \quad (6)$$

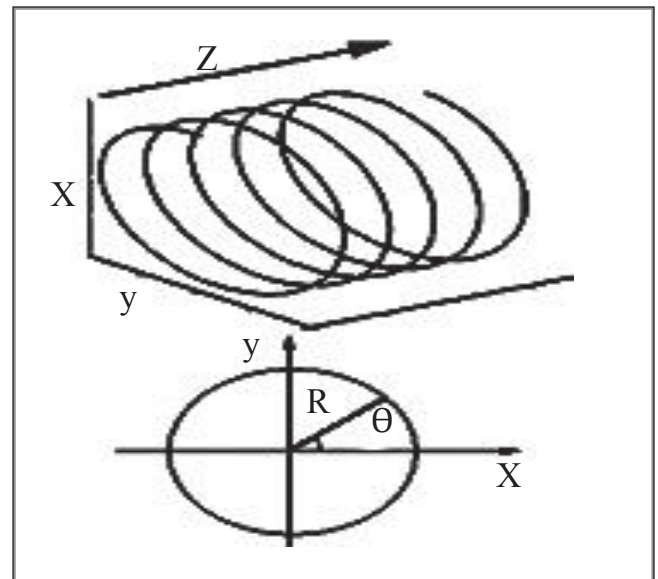
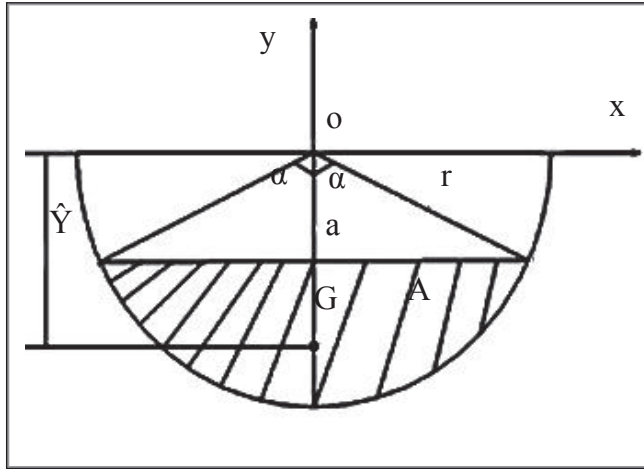

Fig. 2. Helix at coordinate system

**Calculation of transferable volume by helix**

Now, a semicircle is considered to sweep the helix path. Products lie at hatched area (Figure 3).



**Fig. 3. Cut view of semicircle section that sweeps helix path**

Semicircle lies perpendicularly to motion path at the G point (hatched area centroid) for sweeping. Appendix steps are followed for y component calculation of G point ( $\bar{y}$ ). A is the area of hatched zone at Figure 3 then:

$$A\bar{y} = \iint_{\text{sr}} ydA = \int_{-r}^{-a} \int_{-\sqrt{r^2-y^2}}^{\sqrt{r^2-y^2}} ydxdy = \int_{-r}^{-a} 2y\sqrt{r^2-y^2} dy \quad (7)$$

after of solution, result is:

$$A\bar{y} = -\frac{2}{3}(r^2 - a^2)\sqrt{r^2 - a^2} \quad \text{Or}$$

$$A\bar{y} = -\frac{2}{3}r^3 \sin^3 \alpha \quad (8), \alpha(\text{Radian}). \text{ Now, the A is}$$

calculated:

$$A = \iint_{\text{sr}} dA = \int_{-r}^{-a} \int_{-\sqrt{r^2-y^2}}^{\sqrt{r^2-y^2}} dxdy = \int_{-r}^{-a} 2\sqrt{r^2 - y^2}$$

$$\Rightarrow A = r^2 \sin^{-1} \sqrt{1 - \left(\frac{a}{r}\right)^2} - a\sqrt{r^2 - a^2} \quad \text{Or}$$

$A = r^2(\alpha - \sin \alpha \cos \alpha) \alpha$  (Radian). Therefore,  $\bar{y}$  equals:

$$\bar{y} = \frac{-\frac{2}{3}(r^2 - a^2)\sqrt{r^2 - a^2}}{r^2 - \sin^{-1} \sqrt{1 - \left(\frac{a}{r}\right)^2} - a\sqrt{r^2 - a^2}} \quad (10)$$

Or  $\bar{y} = -\frac{2}{3}r \frac{\sin^3 \alpha}{\alpha - \sin \alpha \cos \alpha}$  (11)

Arc length is calculated as follows:

$$s = \int_c ds = \int_{\theta_1}^{\theta_2} \sqrt{\left(\frac{dx}{d\theta}\right)^2 + \left(\frac{dy}{d\theta}\right)^2 + \left(\frac{dz}{d\theta}\right)^2} d\theta \quad (12)$$

According previous equations for helix it can be

written: 
$$\begin{cases} x = R \cos \theta \\ y = R \sin \theta \\ z = \frac{l}{2\pi}(\theta - \theta_0) + z_0 \end{cases} \Rightarrow \begin{cases} \frac{dx}{d\theta} = -R \sin \theta \\ \frac{dy}{d\theta} = R \cos \theta \\ \frac{dz}{d\theta} = \frac{l}{2\pi} \end{cases}$$

Therefore  $s = \int_{\theta_1}^{\theta_2} \sqrt{R^2 \sin^2 \theta + R^2 \cos^2 \theta + \frac{l^2}{4\pi^2}} d\theta \Rightarrow$

$$s = \int_{\theta_1}^{\theta_2} \sqrt{R^2 + \frac{l^2}{4\pi^2}} d\theta = \sqrt{R^2 + \frac{l^2}{4\pi^2}}(\theta_2 - \theta_1)$$

For volume calculation of a part from the helix, appendix equation is correct.

$$v = A.s = r^2(\alpha - \sin \alpha \cos \alpha) \sqrt{R^2 + \frac{l^2}{4\pi^2}}(\theta_2 - \theta_1) \quad (15).$$

Figure 4 shows the volume of calculated part. If helix rotates with rotational speed of  $\omega$  then transferred volume at unit time is  $\omega = \frac{2\pi}{T} \Rightarrow T = \frac{2\pi}{\omega}$  (16), T is the alternation time. It can be written with a simple proportion,  $\begin{cases} T & v_{T,T} \\ 1 & v_{T,1} \end{cases} \Rightarrow v_{T,1} = \frac{v_{T,T}}{T} = \frac{\omega}{2\pi} v_{T,T}$  (17),

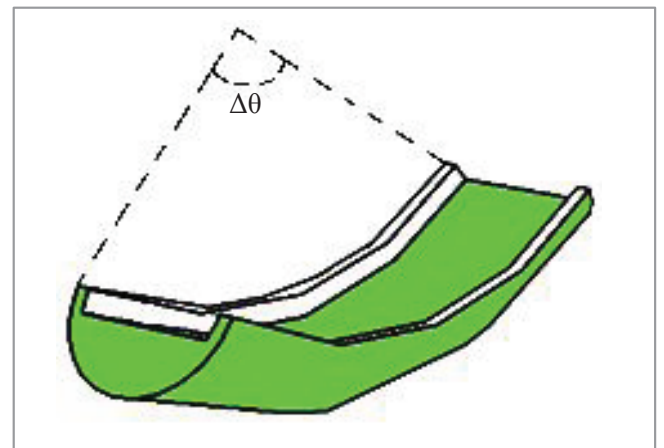

**Fig. 4. Occupied volume of products at helix**

Where  $v_{T,T}$ : transferred product volume at alternation time and  $v_{T,1}$ : transferred product volume at time unit (1s). If transferred product volume at time unit is indicated with  $\dot{v}_T$ , then:

$$\dot{v}_T = \frac{\omega}{2\pi} r^2 (\alpha - \sin\alpha \cos\alpha) \sqrt{R^2 + \frac{l^2}{4\pi^2}} (\theta_2 - \theta_1) \quad (18).$$

It is enough to multiply density ( $\rho$ ) to last equation for converting the volume to transferred product mass at time unit.

Potatoes do not occupy contiguous volume in practical conditions and transferred volume by helix is less. If actual transferred mass is displayed with  $\dot{M}_A$ , the appendix phrase is valid:

$$\dot{M}_A \langle \dot{M}_T \Rightarrow \dot{M}_A = k \dot{M}_T, \quad 0 < k < 1 \quad (19).$$

Therefore, fed products to system ( $\dot{M}_T = Q$ ) can be  $\dot{M}_A$  in the maximum state, namely:

$$Q = \dot{M}_T \leq \dot{M}_A \quad (20).$$

### Summary of effective parameters

The independent and effective parameters on system feed summarized as follows:

$$\dot{M}_A = f(\omega, r, \alpha, R, l, \theta_1, \theta_2) \quad (21).$$

If gradation precision is indicated with P, effective parameters on it consist of:  $P = f(Q, \omega, r, \alpha, b, l, \theta_1, \theta_2) \quad (22).$

### Effect of each helix parameter on gradation

#### Rotational speed

Feed rate increases with addition of rotational velocity. However, precision and damages are limiter factors. Because, product speed increases with augmentation of rotational speed and gradation opportunity decreases. In addition, potatoes contacts with each other at high velocities increase damages. According to Hyde (1997) report, allowed fall height is less than 20 cm at specific humidity and thermal conditions. This height corresponds to contact speed of 1.981 m/s as follows:

$$v^2 - v_0^2 = 2gh \xrightarrow{v_0=0} v = \sqrt{2gh} = \sqrt{2 \times 9.81 \times .2} = 1.981 \quad (23)$$

Estimation of product velocity was complex and difficult because, motion path on helix was 3D and eventuality of product rolling and zigzag movements existed. Therefore, dynamical analysis

software such as Visual Nastran was used. After model preparation and its transfer to mentioned software boundary conditions, constraints and necessary data were defined. Afterward, various rotational velocities were tested with trial and error method until product maximum speed did not exceed fall speed of 1.981 m/s.

#### Feed (Q)

Whatever the feed is high, it takes into account as a positive point until precision do not lessen. Surely, product separation precision is more at lower feeds, in addition scuffing and bruises probabilities are less. With addition of material input volume, likelihood of smaller products positioning at upper parts increases and precision decreases.

Angle of  $\alpha$  (Figure 3) depends on Q, coefficient of rolling and friction. It is not so,  $\alpha$  is independent and we can adjust it on the specific value. Whatever Q is higher,  $\alpha$  close to  $90^\circ$  and whatever be lower, it evanesces. Similar to  $\alpha$ , feed is determinant for  $\theta_2, \theta_1$ . Excessive increase of Q causes product agglomeration at helix middle and precision downfall. Because products cannot take the form of the helix hence, they gather at middle part.

#### Radius of helix and semicircle (R, r)

Relation of transfer volume shows that increase of r augments product transfer volume. In addition, this increase does not affect the precision. Thus, semicircle radius can increase according conditions. As observed at Figure 5 for helix radius it can be written  $R = \frac{b}{2} + \bar{y} - r \quad (24)$ . If b is assignable then R is determined. Enlarging of b can prepare increase of r and R while it has not nocuous effect on the precision.

#### Helix pitch

Pitch length affects product velocity. Whatever pitches length increase, product velocity augments too. In addition, product wends more distance at helix with smaller pitch length. With reference to

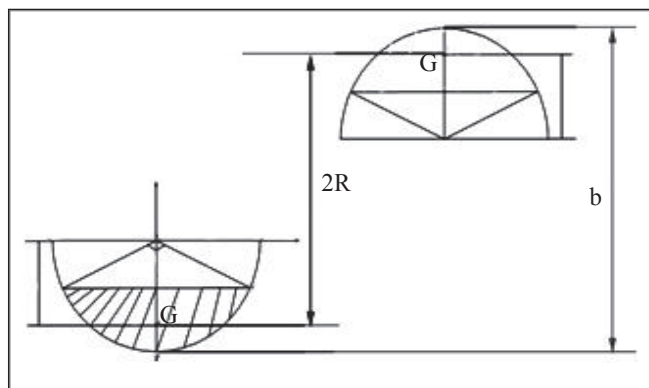

**Fig. 5. Helix side view for perception of relation between b and R**

relation of product transfer volume by helix, increase of pitch length augments transfer volume. When pitch length increases, distance of two consecutive stay increases for pipes. Therefore, precision may reduce because of pipes movement. The smaller pitch is more efficient for helix at slope, because product spillover increases at additional feed. Finally, shorter pitch is preferable with matters pluralization.

**Parameters selection**

One of the goals was connection ability of system to rotary potato harvester until immediately emerged products from ground are graded. Therefore, the diameter of grader cylinder (b) was selected 76 cm for consistency (Azizi, 2007). Shorter pitch length was suitable because of better pipes control and usage at slope (state of connection to potato harvester). Thus, a state was considered that according to Figure 6, helix semicircles positioned side by side. It is true in these conditions  $L = 4D$  (25).

Semicircles could overlap but in this state, system transfer efficiency reduced. Total length of grading cylinder was selected 2.4 m. Reduction of this length lessen the separation length and thereafter gradation opportunity is devested from product. Moreover, mass range of each grade increases that it is not suitable. Since, its flexibility and application diminishes for various objectives. On the basis of 2.4 m length for gradation part and

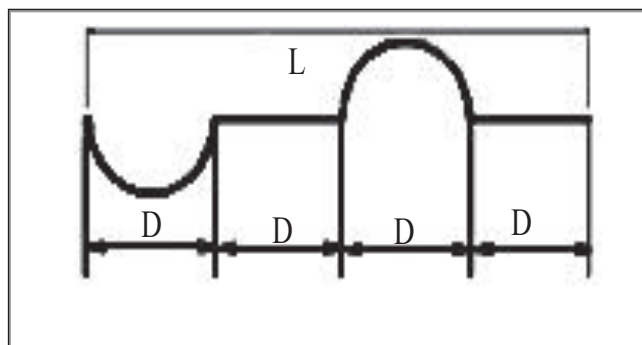

**Fig. 6. Helix side view**

last relation with minimum two pitches, r value is equal to 15 cm. because:

$$2.4 = 4D + 4D = 8D \rightarrow D = \frac{2.4}{8} = 0.30 \text{ m} \quad (26)$$

**Gradation pipes**

Gradation pipes were selected from polyethylene materials. Because, they were cheap and available in addition they reduced weight and required power for rotation. In addition, fewer damages were exerted to potatoes.

Figure 7 shows pipes cross section at a semi-circle of helix. For determination of pipe diameter following points should be attended:

- Semicircle radius and perimeter are 15 cm and  $\pi r$ .
- Initial distance between pipes is two and final eight cm.
- Pipes numbers of helix semicircle generator are 14 at first for suitable grading.
- Lower than six pipes do not appear at last pitch.
- Pipes size should exist at industrial productions.

This equation should be valid for avoiding of semicircle defectiveness:

$$(n - 1)s + nd \geq \pi r \quad (27)$$

n: number of polyethylene pipes

The pipe diameter of 16 mm satisfied mentioned conditions.

**Computer model preparation**

Model was prepared at Mechanical Desktop software. Most important and difficult part of model was cover of gradation cylinder front and

alternation of its circular ring to helix. Figure 8 displays the start stage with some rods. Minimum 500 points were used for design completion and creation of 2 cm distance between rods.

Point coordinates were obtained from helix. Plates were applied for complete conversion of cylinder to helix. These plates aid helix formation and increase products steorage toward inside.

More than 250 points were used for gradation pipes formation at software. Point coordinates are based on helix equation and before data. Important point about pipes is the variable distance between them that it makes gradation. These distances based on measured data and reports of searchers such as Tabatabaeefar (2002) and Ghanbarian et al. (2004, 2010) were selected 2-8 cm for thickness. Since

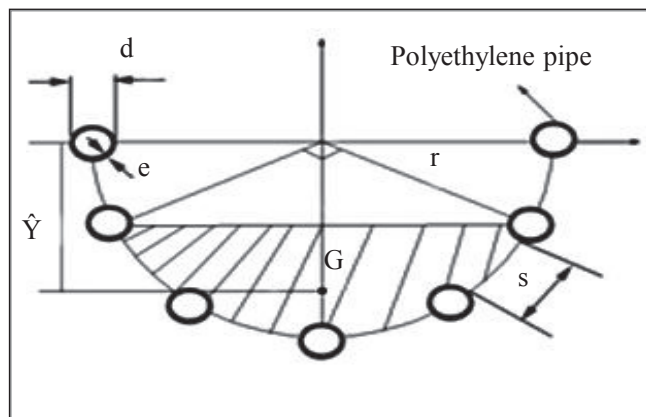

Fig. 7. Gradation pipes cross section at a semicircle of helix

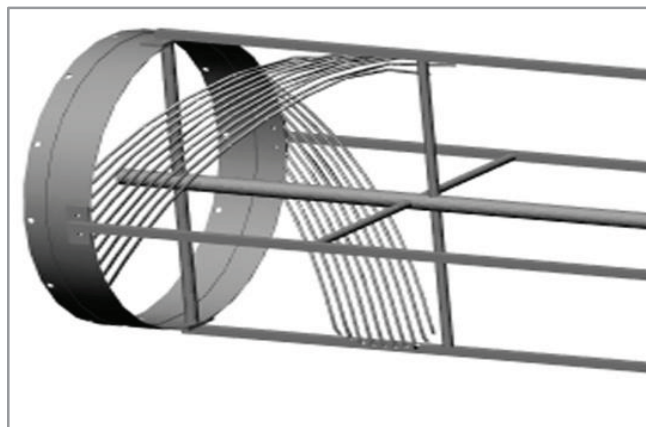

Fig. 8. Start of circular ring conversion to helix

there are eight pitches quarter at system, distance step at each pitch quarter is 7.5 mm. Figure 9 shows the final model and completed aspect. As indicated in figure, pipe numbers decrease at final parts because of their distance increase and additional sections should be cut at appropriated sites.

Pipes were connected to gradation cylinder by rivet, metal sheet and finally weld at any pitch quarter. A thin ring was jointed on cylinder front edge for avoidance of products outpouring from cylinder (Figure 9).

### Potato model

Potato has three orthogonal axes and from a geometric point of view is ellipsoid. Engineering software programs have not ellipsoid as a prefabricated model. Therefore, ellipse was modeled at Mechanical desktop software with mean of Ghanbarian et al. (2004, 2010) data and division of each  $90^\circ$  into 18 parts (rectangles) of  $5^\circ$ .

### Coefficient of friction measurement

Inclined plate was used for measurement of static Coefficient of friction. A plate was made with polyethylene pipe. Then some potato from Agria and Morfana (Agria and Morfana occupy 72600 hectares i.e. almost 50 % area of potato plantation in Iran (Ghanbarian et al., 2004, 2010) varieties were selected and static Coefficient of friction was calculated with ten repeats.

### Construction

Various stages of pieces construction were done with consideration on presented matters at before parts. Figure 10 shows the total side view of system. Just as observed at figure, helix was rotated by tractor PTO with using of universal joint, belt and pulley, gearbox, chain and sprocket wheel. This power transmission system successfully was applied for reducing PTO speed up to desirable level and diminishing PTO rotational speed of 540 on 9 RPM.

### ***Study of potato physical properties related to gradation and system operation***

Potato physical properties are very important parameter to systems design of gradation, transmission, processing and packing. Characteristics such as dimension, volume, projected area and mass centroid have special importance. Three sample potatoes were chosen as indicants of small, mean and large based on Ghanbarian et al. (2004, 2010) data. These potatoes positioned once separately and other time cumulatively into helix for analysis with Visual Nastran software. Results corroborated the gradation based on height. Finally, three sample potatoes were picked out for comparison of software result and actual situation then gradation was done with five repeats for any one. Separation was seen based on height at total states. In addition, Butler (2005) introduced the minimum diameter as a segregation criteria at himself cylindrical grader.

From two varieties of Morfana and Agria, whichever 100 samples were selected for determination of relation between mass and height. Their mass and height were measured using digital balance with accuracy of 0.01 g and caliper (0.1 mm). The mass equation with thickness was estimated for 200 data at Excel software. Between linear, power, logarithmic, exponential and polynomials with orders of 2, 3 and 4 regressions whichever had maximum  $R^2$  were chosen. Mass ranges of product separation were under 50, 50-80 and above 80 g. Therefore, connected thicknesses (heights) to mass range of 50-80 g were estimated according to obtained equation. Matlab software was used for solution of polynomials equations with orders of four. The results were applied for position determination of separator plates.

First, separator plates positioned at situation that equations results expressed. Then, separation precision of system with practical experiments was measured. The precision is products percentage that graded correctly at a special grade. A series

experiments were executed on the form of trial and error at higher and lower positions of calculate values. Finally, the best situations of separator plates were chosen.

## **Results and Discussion**

Static coefficient of friction between polyethylene pipe and potato was obtained for Morfana and Agria respectively 0.5583 and 0.4531. T-test was applied for two means comparison. T value of table for confidence level of 0.01 was number of 3.25 and measured t for data was 5.39. Therefore, the difference between means was significant with 99% confidence that it indicates differences in varieties or conditions. A point is necessary to mention that static coefficient of friction was used instead of dynamic at computer simulation, because its measurement is simple and cheap. According

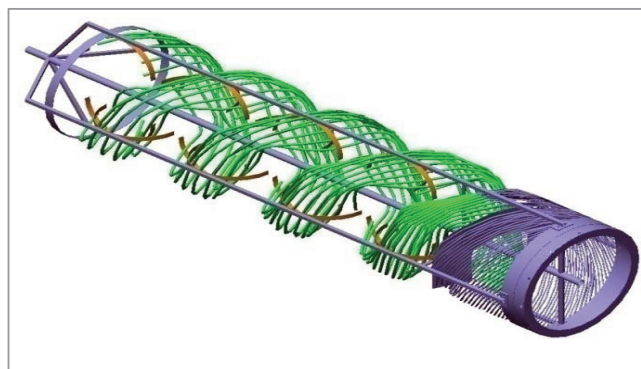

**Fig. 9. Isometric view of gradation helix model**



**Fig. 10. Side view of connected system on tractor**



to Schaper (1999) research, static coefficient of friction is approximately 10% higher than dynamic. Results of product mean velocity at software pointed out difference of 7% that it was waived.

Outbreak of product damages at maximum velocity (1.981 m/s) was avoided according to result of Visual Nastran software at rotational speed of 20 RPM and maximum limit of force does not exceed 10 N (large potato mass is 1 Kg). Therefore, three concentrated forces of 10 N were used at Ansys software for analysis and loading. Result of polyethylene pipe deformation was maximum deformation of 1 cm. This value concerns to a potato with approximate width of 10 cm, hence pipes movement about one cm dose not hamper gradation and affect precision.

Figure 11 shows forces at site of pipes connection to gradation.

Finally, 22 N was exerted on each pipe with force division on number of engaged pipes. These same matters were propounded for torque. Torque of each pipe portion was 7.4 N.m. The pipe was analyzed at ANSYS software with calculated force and torques in the connection site. Stress of 6.2 Mpa versus yield stress of 22.05 Mpa showed that there was no problem.

Figure 12 exhibits result of the best regression equation for Morfana variety.

Table 1 displays the results of equations solution for considered mass range.

Several tests were done at practice and precision was measured. At end, the numbers of 35 and 45 mm for Morfana and 28 and 33 mm for Agria presented the best condition of precision. Therefore, separator plates situated according these distances between pipes.

Required torque for rotation of gradation helix was studied at maximum load similar to before mentioned states by Visual Nastran software. It assumed that helix speed achieved on practical speed of 9 RPM at one second. Figure 13 indicates the helix torque with presence of products.

In consideration of graph data, the torque magnitude does not become zero after one second because friction and products rotation do not allow. Maximum torque of 50 Nm was calculated according the graph and loading manner. For taking into account frictional force on bearing and ... coefficient of 1.5 was multiplied and final torque of 75 Nm was selected. Thus, the power is equal to 71 Watt.

The ability of product transfer by rotary helix approximately consists of:

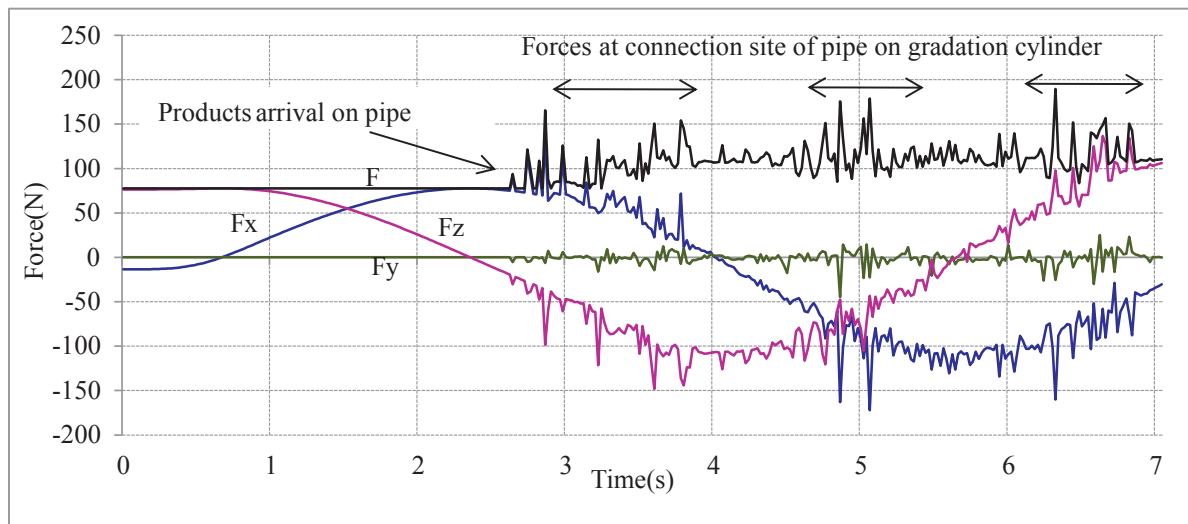

Fig. 11. Exerted forces graph at site of pipe connection to cylinder with presence of products

$$\dot{M}_T = \frac{\omega\rho}{2\pi} r^2 (\alpha - \sin\alpha \cos\alpha) \sqrt{R^2 + \frac{l^2}{4\pi^2}} (\theta_2 - \theta_1) \quad (28)$$

Based on chosen quantities for each parameter, the system can transfer 4.69 tons per one hour. Because of two helixes usage together according figure (9), the transfer mass is two times of last equation result. Theoretical and actual volume in practice surely is less because products do not make the continuous volume. A series tests were executed for estimation of the maximum transfer mass so that the system choked with additional input product. Result was 0.833 Kg/s or nearly 3 tons/hour.

Partial differentiation of  $\dot{M}_T$  versus each variable was done based on before calculated data. For instance, speed derivative is:

$$\frac{\partial \dot{M}_T}{\partial \omega} = \frac{\rho}{2\pi} (\alpha - \sin\alpha \cos\alpha) (\theta_2 - \theta_1) r^2 \sqrt{R^2 + \frac{l^2}{4\pi^2}} = 0.009048 \quad c(29)$$

**Table 1**  
Results of equations solution (unit mm)

Variety	Correspond height with 50 g	Correspond height with 80 g
Morfana	36.36	42.68
Agria	29.55	31.66

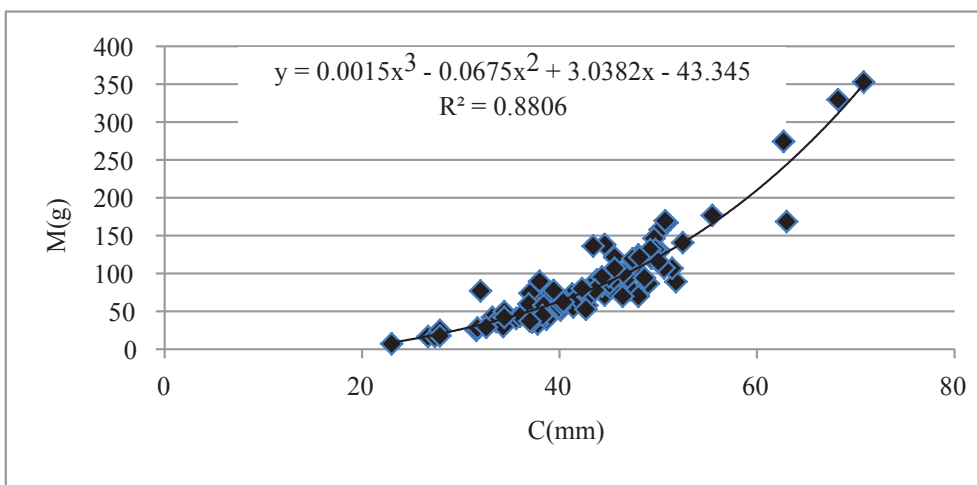

**Fig.12. Points dispersion quality and best regression equation between mass and thickness for Morfana variety potato**

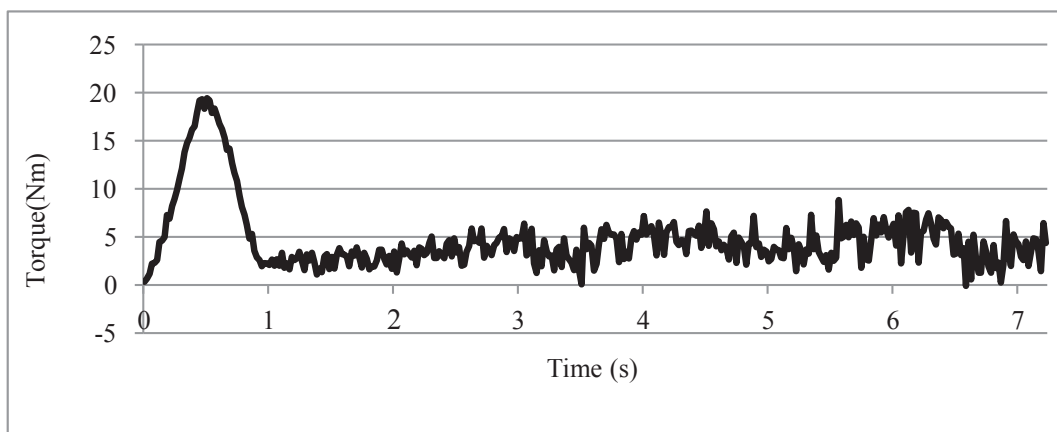

**Fig. 13. Required torque graph for rotation of helix with presence of products**

Hence the variables importance arrangement at transfer mass amount appeared. Effect intensity of variables from strong to weak consists of  $r$  (radius of semicircles that form helix),  $R$  (helix radius), rotational speed and finally pitch length. The  $r$  and  $R$  are more effective and worthy of attention. This point is a good guidance for any new variation and manipulation. On the other hand taking of small pitch length do not very affect the transfer mass. In addition, reduce of rotational speed is good for precision and it do not create so variation at the transfer mass.

## Conclusion

Obtained results are summarized as follows:

- Theoretical and practical transfer mass is respectively 4.69 and 3 tons/hour.
- Maximum rotational speed is 20 RPM for avoidance of damages.
- Required torque and power for system consist of 75 N.m and 71 Watt.
- Results of partial differentiation showed effective parameters at system from strong to weak are  $r$ ,  $R$ ,  $\omega$  and  $l$ .
- Gradation was based on mass with range of 50-80 g for seed potatoes.
- Position of separator plates correspond to polyethylene pipes distance up to 35 and 45 mm for variety of Morfana and 28 and 33 mm for variety of Agria.
- Application of polyethylene pipes was successful and suitable pipe size obtained 16 mm.
- Static coefficient of friction between potato and polyethylene pipe was acquired respectively for Morfana and Agria variety 0.5583 and 0.4531.

## Acknowledgements

It is gratefully acknowledged from cooperators in Shahrekord university workshops, Dr. Ghanbarian and Dr. Eshaghbeigi.

Received April, 2, 2011; accepted for printing February, 2, 2012

## References

- Azizi, P.**, 2007. Rotary potato harvester blade. M.S. Thesis. Agricultural Machinery Department, Shahrekord University, Iran (Fa).
- Bohl, W. H., P. Nolte, G. E. Kleinkopf and M. K. Thornton**, 1995. Potato seed management: seed size and age. Univ. of ID Coop. Ext. Sys. CIS 1031.
- Butler, G. P., T. Bernet and K. Manrique**, 2005. Mechanization of potato grading on small- scale farms: A case study from Peru. *Expl. Agric.*, **41**: 81-92.
- Ghanbarian, D., N. N. Kolchin, S. R. Hasan Beigi and R. Ebrahimi**, 2010. Design and Development of a small potato-grader machine using Capron net. *Journal of Food Process Engineering*, **33** (6) 1148–1158.
- Ghanbarian, D., V. M. Khalancki and N. N. Kolchin**, 2004. Design and Development of a universal grading machine for potatoes. Agricultural Machinery Department, Moscow, Timiriazev (Ru).
- Hyde, G. M.**, 1997. Potato Impact Damage Thresholds. *Trans. of the ASAE*, **40** (3): 705-709.
- Iritani, W. M. and R. E. Thornton**, 1984. Potatoes: Influencing Seed Tuber Behavior. PNW 248, 15 pp.
- Jacob, F. C., R. J. Romani and C. M. Sprock**, 1965. Fruit sorting by delayed light emission. *Trans. Am. Sot. Agric. Eng.*, **8**: 18-19.
- Jenkins, C.**, 1992. Potato grader. United state patents. No. 1345858.
- Johnson, S. B.**, 1997. Potato Facts – Selecting, cutting and handling potato seed. University of Maine Cooperative Extension. Bulletin #2412.
- Mohsenin, N. N.**, 1986. Physical Properties of Plant and Animal Materials. Gordon and Breach Science Publishers, pp. 20–89.
- Noordam, J. C., G. W. Otten, A. J. M. Timmermans and B. H. van Zwol**, 2000. High-speed potato grading and quality inspection based on a color vision system. Machine vision and its applications, San Jose (USA): SPIE, pp. 206-220.
- Peleg, K.**, 1985. Produce handling, packaging, and distribution. The AVI Publishing Company. Inc. Westport, Connecticut, pp. 55–95.
- Schaper, L. A. and E. C. Yaeger**, 1992. Coefficients of friction of Irish potatoes. *Transactions of ASAE*, **35**(5): 1647-1651.
- Shaym, M.**, 1990. Design and development of potato grader. *Agricultural Mechanization in Asia, AMA*, **21**(1): 40-42.
- Tabatabaefar, A.**, 2002. Size and shape of potato tubers. *Int. Agrophysics*, **16**: 301-305.