

Research and formation of qualitative hydro air ion composition in agricultural premises

Serhii Sukach¹, Tatyana Kozlovskaya¹, Ihor Serhiienko¹, Valentyn Glyva², Oleksandr Vovna³, Ivan Laktionov^{3*}

¹*Kremenchuk Mykhailo Ostohradskyi National University, 39600 Kremenchuk, Ukraine*

²*National Aviation University, 02000 Kiev, Ukraine*

³*State Higher Education Institution “Donetsk National Technical University”, 85300 Pokrovsk, Ukraine*

*Corresponding author: ivan.laktionov@donntu.edu.ua

Abstract

Sukach, S., Kozlovskaya, T., Serhiienko, I., Glyva, V., Vovna, O., & Laktionov, I. (2019). Research and formation of qualitative hydro air ion composition in agricultural premises. *Bulgarian Journal of Agricultural Science, 25(2)*, 256–263

An approach to establishment of the mechanism of formation of air and hydro air ions on the example of greenhouses has been studied and proposed. Ways of determining energy of ionization (formation) of air ions by energy values of breakdown of chemical bonds have been shown in order to evaluate the probability of formation of air ions of different chemical structures. It has been established that the use of a small ultrasonic air ion generator helps to normalize air ion composition of the air without generation of harmful substances and purifies the air from fine particles that absorb air ions and reduce electrification of dielectric surfaces. Due to the balloelectric effect, the negative effect inherent in most existing ionizers (generation of ozone and nitrogen oxides) minimizes, which improves the quality of the internal air and, thus, increases level of comfort and efficiency of workers of agro-industrial complexes. Intellectual internal air quality control system with the use of fuzzy-logic has been developed and implemented. The optimality criterion of the control system for working zone comfort and standardized parameters of microclimate and air ion concentration in the working zone have been proposed.

Keywords: air quality control system; air ion concentration; air ionization; air quality; ventilation system

Abbreviations: DV – displacement ventilation, ACS – automatic control system, IAQCS – internal air quality control system, PMV – predicted mean voice, AM – asynchronous motor, FK – frequency converter, VR – voltage regulator

Introduction

Surrounding external and internal environment is a complex dynamic system, which is a complex of interaction and inter conversion of various factors of physical, chemical, biological nature.

Artificial air ionization has a beneficial effect on all living organisms – humans, animals, plants, located in the premises where there are no natural negative ions of oxygen. It has become essential in recent years due to the development

of intensive technology of crop cultivation and raising farm animals and birds. Masscharacter of animal housing, use of metal cages, reinforced concrete structures reduce concentration of negative air ions in the air of agricultural premises.

Studies conducted by Chyzhevsky and his colleagues have shown that negative ions of oxygen accelerate germination and growth of seeds, give faster and healthier seedlings, increase leaf area intensity of their chlorophyll colour, increase wet and dry weight, enhance plant respiration and their enzymatic processes. Thus, the degree of wheat germi-

nation increased by 22%, beetroot – by 4%, soybeans – by 20%, beans – by 18%, lentils – by 25% (Chizhevsky, 1999).

A.L. Chizhevskiy, V.P. Skipteroviy and A.P. Yesipoviy (Skiptetrov, 2005) obtained interesting results while aerating greenhouses with air ions, where the content of negative ions of oxygen due to the high humidity of air usually reduces to a minimum. Sessions of air ionization began one month after planting different plants to the ground. The harvest of cucumbers doubled. Other experimental greenhouse crops (salad, radishes, dill, spinach, tomatoes, courgettes) noticeably increased. The obtained facts convincingly indicate that negative ions of oxygen can significantly increase the productivity of greenhouse farms.

The conducted studies proved that the effect of negative ions of oxygen occurs by means of colloids of plant cells. It is assumed that the effect and aftereffect of negative ions of oxygen comes down to their assimilation by cell colloids, proteins, lipoproteins and enzymes. Plant protein particles have a negative charge on their surface. Addition of electrons, brought by negative ions of oxygen, accelerates intracellular processes, changes the rate of physical and chemical reactions and thereby stimulates vital activity of plant cells. However, all these assumptions about the mechanisms of negative ions of oxygen require the most explicit study using modern research methods.

In addition, chemical composition of the internal atmospheric air of agricultural premises may be accompanied by appropriate chemicals that are formed in a variety of technological processes in greenhouse farms. In order to remove these harmful substances, for supplying air to the premises and artificial air ionization we need to introduce organizational and technical measures, one of which is the use of modern ventilation systems. Thus, studies of Sukach and Zaporozhets (2014) suggest the use of automated control systems for airspace parameters. However, in many cases, premises are supplied with external air with unsatisfactory air ion concentration of either both polarities or one polarity (Sukach, 2015). In the study of Belyaev and Tsygankova (2015) the air ionic mode of the working zone is determined for the air artificial ionization. The advantage of these studies is the suggestion of using scattering screens for uniform distribution of ionized air in the environment. Nevertheless, this does not solve the problem of controlling levels of air ionization and managing operating modes of the ionizer. This necessitates regulation of this parameter in the automatic mode with continuous or periodic determination of air ion concentration of both polarities.

However, normalization of the air ion composition in the premises of greenhouse farms without taking into account main parameters of microclimate (temperature and relative

humidity) has no prospects because these factors are interconnected (Sukach, 2014). Acceptable quality of the internal air (Fanger, 2003) can only be obtained through the implementation of monitoring and management of the set of the listed indicators.

The purpose of the article is to develop theoretical and practical research on improvement of the level of comfort and efficiency of workers of agro-industrial complexes and the quality of cultivated crops, raising agricultural animals and birds using the developed modern intellectual internal air quality control system in agricultural premises with an ultrasonic generator of hydro air ions.

Materials and Methods

The article deals with the topical scientific and applied problem of method justification, as well as mathematical model of establishment of patterns of hydro air ion emission development of a quality control system for indoor air in agricultural premises using fuzzy-logic.

The research is based on fundamental principles of thunderstorm electricity physics, physical and chemical patterns of formation of air ions and hydro air ions, theory of experiment planning, computer and simulation modeling.

Experimental data were obtained in the laboratories of the Department of Systems of Automatic Control and Electric Drive of Kremenchuk Mykhailo Ostrohradskiy National University and the Department of Electronic Engineering of Donetsk National Technical University of the Ministry of Education and Science of Ukraine on physical models using computer-measuring systems and metrologically certified measuring instruments.

Simulation of the developed system and processing of the results were performed in modern application packages Mathcad, Microsoft Excel, NI LabView.

The research results were implemented within state-financed research of Kremenchuk Mykhailo Ostrohradskiy National University: ‘Development of methods and tools for control and quality assurance of air environment on the premises’, ‘Development and launch of the automated control system of the control complex for air parameters and safety devices of insulated premises’, ‘Development of methodical and metrological support for computerized electromechanical complexes, implementation into teaching process and research’, ‘Efficiency increase of electronic devices and systems’, ‘Development of intelligent measurement modules for electronic systems for monitoring physical media parameters’, ‘Development of method and tools for efficiency increasing of computerized information and measuring systems of technological processes’.

Results

Conducting experimental studies, we established that nomenclature and content of chemicals capable of producing air ions under certain conditions in the air of agricultural premises are very diverse, depending on industrial load of the territory from which the air enters the premises, availability of production equipment, etc. This is carbon dioxide, hydrogen sulfide, nitrogen dioxide, ammonia, sulfur dioxide and silicon. These chemicals form air ionic composition of the air in the room, and hydro air ion composition with changing air humidity. These components are always present inside greenhouses, as greenhouse soil contains silica. Nitrogen-nitrifying bacteria synthesize ammonia which also enters the room. The same processes contribute to the formation of hydrogen sulfide through functioning of sulfur-reducing bacteria.

The study of biochemical soil processes allows us to establish the possibility of formation of air ions and hydro air ions by means of concentration of other components in the atmosphere, which is several orders of magnitude lower than concentration of naturally present substances, but in terms of chemical activity (by the values of ionization energies), they can easily form positively and negatively charged air ions or air ion radicals:

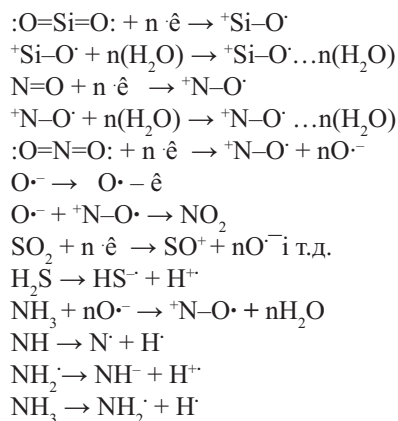

It should be noted that the higher ionization energy of an atom, the easier an air ion is formed, and vice versa – the ionization energy must be sufficiently low for molecules to give rise to an air ion with a positive or negative charge.

This approach allows us to describe the process of air ion formation or their recombination as a simple attachment or detachment of electrons according to the following scheme:

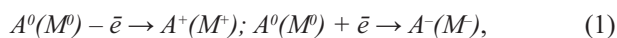

where $A^0(M^0)$ is a neutral atom or molecule; $A^+(M^+)$ and $A^-(M^-)$ are positive or negative formed air ions, respectively.

During the research, the energy of activation of the possible formation of air ions with the use of corresponding heat of breaking chemical bonds in atoms, molecules and radicals was determined (see Table 1).

$$A_n[A_n B_m] = -n \cdot Q + 2m \cdot q + x \cdot v_1 + y \cdot v_2 + z \cdot v_3, \quad (2)$$

where Q is energy of attachment or detachment of one electron; q is heat of formation of corresponding bonds (tabular data); v_1, v_2, v_3 (m) are heat of formation of substances forming the air ion or complex ‘air ion-chemical’ with single, double or triple bonds on Hess equation; x, y, z is the number of single, double or triple chemical bonds in corresponding molecules.

Table 1. Ways of formation of air ions under the breakdown of chemical bonds in atoms, molecules and radicals

Reaction	Activation energy of probable formation of air ions		Energy of ionization	
	eV	kJ/mol	eV	kJ/mol
$H_2 \rightarrow 2H$	4.39	418.9	4.57	436.0
$H_2^+ \rightarrow H + H^+$	2.05	195.6	2.68	255.7
$H_2O \rightarrow HO\cdot + H$	6.16	594.02	5.17	498.7
$H_2O_2 \rightarrow 2OH\cdot$	1.98	188.9	2.22	214.0
$H_2S \rightarrow HS\cdot + H^+$	4.05	386.9	3.99	385.0
$NH \rightarrow N\cdot + H$	2.99	285.3	3.24	313.0
$NH_2\cdot \rightarrow NH\cdot + H^+$	4.02	383.6	4.36	421.0
$NH_3 \rightarrow NH_2\cdot + H$	4.22	402.7	4.54	438.0
$NO \rightarrow N\cdot + O\cdot$	5.95	567.8	6.55	632.0
$NO_2 \rightarrow N\cdot + O_2$	3.64	347.3	4.55	439.0
$NO_2 \rightarrow NO + O\cdot$	3.98	379.8	3.17	306.0
$O_2 \rightarrow 2O\cdot$	4.96	473.3	5.17	498.4
$O_2^+ \rightarrow O\cdot + O^+$	5.76	549.6	6.67	643.3
$O_2^- \rightarrow O\cdot + O^-$	4.32	432.0	4.11	397.0
$O_3 \rightarrow O_2 + O$	0.99	94.5	1.11	107.0
$SO_2 \rightarrow SO\cdot + O\cdot$	4.99	476.1	5.71	550.6
$\cdot CH \rightarrow C + H\cdot$	3.64	347.3	3.51	339.0
$CH_2O \rightarrow CHO\cdot + H$	3.55	338.7	3.77	364.0
$CHO\cdot \rightarrow CO + H$	0.65	62.2	0.80	77.4
$CH_4 \rightarrow CH_3 + H\cdot$	4.32	432.0	4.51	435.0
$(COOH)_2 \rightarrow 2COOH\cdot$	1.79	170.8	1.85	178.0
$\cdot COOH \rightarrow CO\cdot + \cdot OH$	1.05	100.2	0.99	96.0
$\cdot COOH \rightarrow COO\cdot + H$	2.05	197.3	1.62	155.9

Analysis of the results proves (see Table 1) that the estimated data differ from the known tabular data by $\pm(5-15)\%$. This allows us to say that activation energy of air ion formation can serve as a criterion for assessing probability of formation of the corresponding charged particles.

In addition, analysis of many series of measurement did not reveal a direct relationship between changes in air ion concentration with some predominant factor in air ionization (deionization). Obviously, this is due to the combined effect of a number of factors, each of which affects the quality of the indicators on the verge of measurement error – these are indicators of the outside air, the number and operating modes of electrical and electronic equipment in the room, the number of people, concentration of fine particles in the air, levels of electrification of dielectric surfaces, and so on. In such conditions it is advisable to control air ion concentration continuously or with the required periodicity. To automate the control process, it is feasible to use an air ion counter with a standard port for connecting a personal computer. The widespread device is a reliable ‘Sapphire 3K’ meter equipped with a RS 232 port.

A more complex task is the choice of a functionally acceptable air ionizer. Almost all serial devices are variations of the well-known ‘Chyzhevsky chandelier’ and work with corona discharges. Along with positive characteristics – air ion generation in required quantities, regulation of generation of air ions of the desired polarity – these devices have critical weakness that is generation of ozone and nitrogen oxide in unpredictable quantities, which is inherent in all high-voltage discharges. This suggests feasibility of ionizers, since formation of toxic ozone and nitrogen oxides increases the risk of adverse effects on workers on the premises of greenhouse farms.

If catalytic ozone absorbers are used in some modern ionizers, removal of nitrogen oxides from the air is very problematic and it is not used in air ionizers. Ozone in large quantities and all nitrogen oxides are known to have an adverse effect on the human body, farm animals, birds and plants. Therefore, it is important to search for other means of air ionization, which do not have side effects. It is known that the ionization factor is the balloelectric effect – air ionization during mechanical water pulverization. Therefore, the best natural air quality indicators for air ion composition are observed on the seashore in surf zones.

Based on physical considerations, it should be expected that the ultrasonic emission of water will be the most effective.

In connection with the above mentioned, a series of experiments was conducted using a small ultrasonic generator of 10 W power, 24 V voltage, and resonance frequency of 1.7 MHz.

The first studies were carried out in order to determine dependence of changes in air ion concentration under the balloelectric effect, when a thin jet of drinking water was fed to the inoperative membrane of the ultrasonic generator,

and when the water was completely ground with ultrasonic waves.

Analysis of the experimental data (see Figure 1) suggests that even with the use of a low-power ultrasonic air ion generator, concentration of negative air ions at a distance of 0.3 m quadrupled, while the concentration of positive air ions does not change.

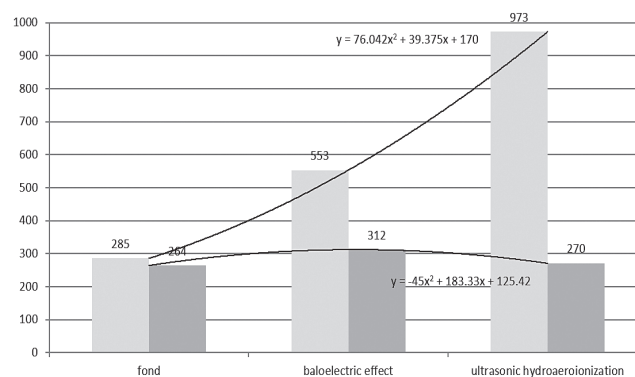

Fig. 1. Dynamics of air iron concentration under the balloelectric and ultrasonic hydro-aerodynamic effects in drinking water

Literature analysis proved that the mechanism of formation of light ions under destruction of the water surface is rather unclear. Thus, research carried out by J.I. Frenkel, J. Simpson, A.N. Frumkin, V.M. Muchnikov, B.J. Mason, P.R. Jonas and other scientists have opposite and contradictory results. However, most experiments confirm our studies that concentration of only negative air ions increases with the balloelectric effect.

In our opinion, this phenomenon may be related to the physical impact on water molecules located on the surface of liquid as a double electric layer under the influence of ultrasonic waves and additional quasipiezoelectric effect due to the applied mechanical tension. Since water molecules are dipoles that are interconnected by electrostatic interaction and intermolecular hydrogen bonds, under the influence of ultrasonic waves, their breakdown and release of individual water molecules as vapour occurs.

At the next stage, it became necessary to establish patterns of changes in hydro air ion concentration depending on the distance to the ultrasonic air ion generator, and the use of drinking water (Fig. 2) and distilled water (Fig. 3).

When using distilled water, concentration of hydro air ions at a distance of 0.3 m from the ultrasonic air ion generator increases almost twice compared with drinking water, which, in our opinion, is due to the absence of mineral salts, microelements and various impurities in it. Drinking water

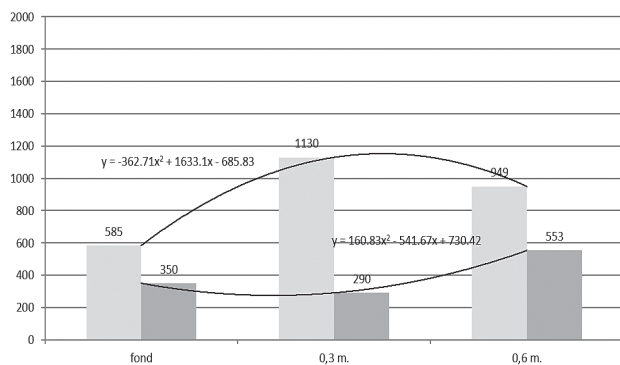

Fig. 2. Dynamics of hydro air ion concentration with the distance to the ultrasonic air ion generator using drinking water

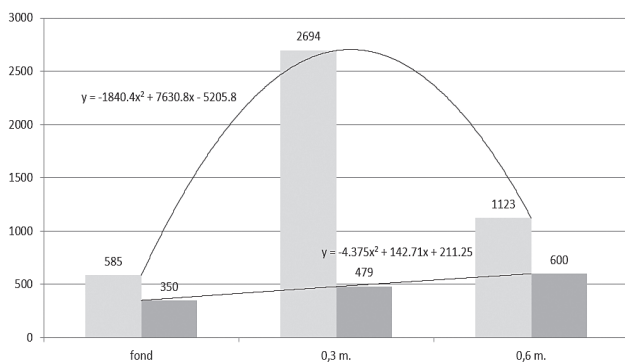

Fig. 3. Dynamics of hydro air ion concentration with the distance to the ultrasonic air ion generator using distilled water

is a solution of a mixture of strong and weak electrolytes. Mineral constituent of water is ions Na^+ , K^+ , Ca^{2+} , Mg^{2+} , Cl^- , SO_4^{2-} , HCO_3^- . Due to this, the specific electrical conductivity of drinking water (2–3 mSm/cm) is much greater than that of distilled water (less than 5 $\mu\text{Sm/cm}$). And as water is a polar fluid, in which molecules are dipoles, due to lower electrical conductivity of distilled water, the balloelectric effect significantly increases with the use of ultrasound. In addition, there is a decrease in concentration of positive air ions, since Na^+ , K^+ , Ca^{2+} , Mg^{2+} , Cl^- , SO_4^{2-} , HCO_3^- ions form a hydrated form ($\text{Me}^{n+} \cdot n\text{H}_2\text{O}$; $\text{A}^{n-} \cdot n\text{H}_2\text{O}$) with a higher molecular weight than the corresponding negative air ions that exist in the air. Hydro air ions have less mobility than air.

But at a distance of 0.6 m, there is a recombination of positive and negative air ions and mixing of artificially formed hydro air ions with the existing air composition in the room, which contributes to the gradual alignment of air ion concentration.

For distilled water the surge in negative hydro air ion concentration is also observed at a distance of 0.3 m ($2\text{H}_2\text{O} \rightarrow \text{H}_3\text{O}^+ + \text{OH}^-$), and then influence of direct air ions is predominant, due to the addition of other constituents of air (SiO_2 , NO_2 , NO , H_2S , SO_2 , NH_3) in greenhouse buildings.

The conducted experimental studies have shown that the use of the ultrasonic air ion generator reduces the amount of ozone by almost 50%, and NO^+ ions – by 4.5 times due to the presence of water vapor – H_3O^+ and OH^- . Ozone cannot form ions, as noted in many literature references, but decomposes into oxygenic radical (O^+ , O^-) and the molecule of oxygen (O_2).

Consequently, having conducted research, we found that the given method of air ionization is expedient to use on the premises with highly deionized air, which requires significant amounts of air ion generation and which includes the premises of greenhouse farms. But in order to distribute hydro air ions generated with ultrasound, it is necessary to create air streams which are controlled both at speed and direction. Consequently we suggest using a ventilation system.

Ventilation systems must comply with a number of special requirements, namely principal provisions of the European associations and societies of heating, ventilation, air conditioning – ASHRAE, IIR, CIB, Eurovent, Unichal, REHVA (Dyment, 2014): not to increase the level of fire hazard; not to create high noise levels; provide static electricity removal; fans used in explosive and fire hazard premises should be made of materials that do not cause sparks.

Field measurements performed on the premises of Kremenchuk Mykhailo Ostrohradskyi National University proved that changes in air ion concentration of both polarities (both individually and together) with the use of the ventilation system are significantly reduced (Fig. 4, a, b).

In order to ensure convenient placement of the air ion generation system (regulated pump and ultrasonic air ion generator with control system) we suggest the use of modern automated DV.

In DV systems, inflow air is fed from the floor level directly to the service area. In this case, its temperature should be lower than the air temperature in the room ($\Delta t = 1-8^\circ\text{C}$). If the inflow air is more than 3°C colder than the air in the room, then it should be mixed with the air in order to avoid sense of discomfort for people from cold air streams at the floor level. Removal of heated contaminated air, which is displaced to the upper zone, occurs at the ceiling level of the room due to convectional flows over heat sources.

The main advantages of the displacement ventilation are a significant increase in air quality and creating comfortable conditions in the working zone. High efficiency of air exchange ventilation displacement at least twice reduces

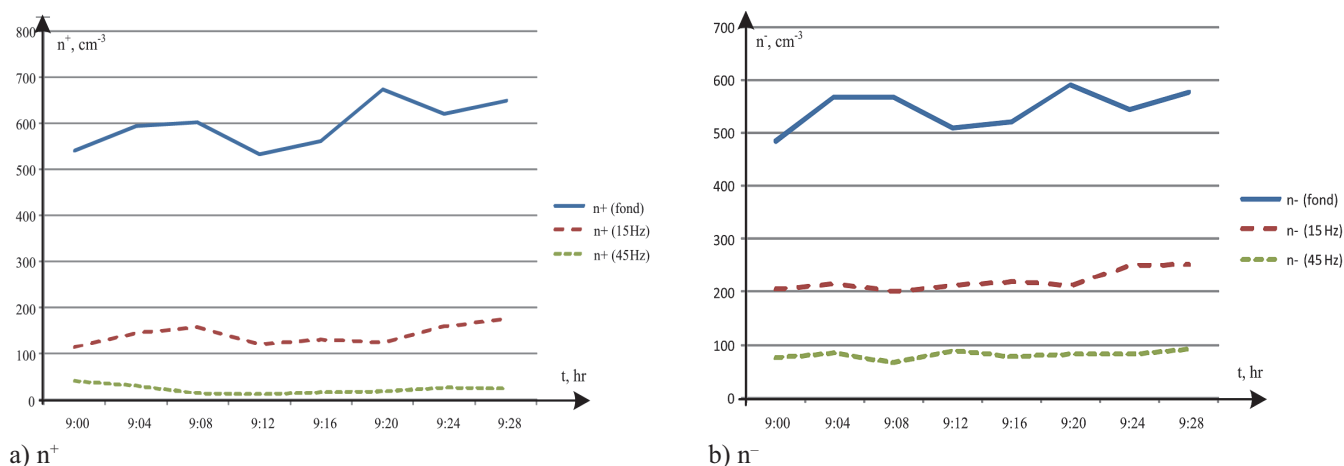

Fig. 4. Graph of positive (n^+) and negative (n^-) air ion changes in the laboratory room at a distance of 2 m from the ventilation grating depending on the rotation speed of the fuel fan (15, 45 Hz)

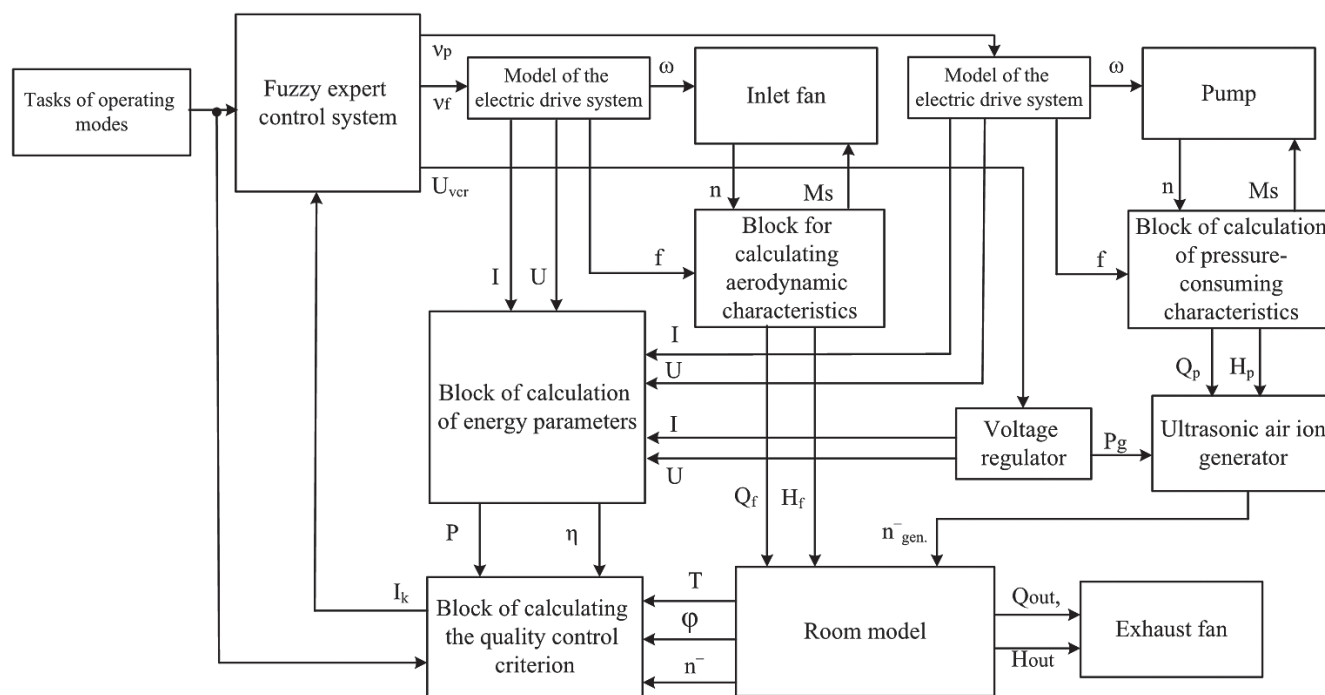

Fig. 5. Block diagram of the internal air quality control system (IAQCS) using fuzzy-logic: T – temperature, $^{\circ}\text{C}$; ϕ – humidity, %; n^- – concentration of negative air ions, cm^{-3} ; I – current, A; U – voltage, V; η (eta) – fan efficiency; P – fan power, W; P_g – generator power, W; U_{ver} – voltage control of the voltage regulator of the ultrasonic air ion generator, V; n_{gen}^- – concentration of generated air ions, cm^{-3} ; f – frequency of the frequency converter for supplying the AM of the fan (pump), Hz; n – frequency of fan (pump) rotation, rpm; M_s – static resistance of the fan (pump), N·m; H_p – pump head, m; Q_p – water consumption, m^3 per year; Q_f – air consumption, m^3 per hour; H_f – air pressure at the fan outlet, m^3 per hour; I_k – management quality criterion; v_f – control signal of fan speed; v_p – control signal of pump speed

carbon dioxide content and other harmful substances in the breathing zone of workers.

However, the conducted studies (Sukach, 2014) have shown that normalization of air ion composition of the air without monitoring and control of microclimatic parameters is impossible. In connection with this, there is a need to create an automatic control system, which would provide maximum quality of internal air in the working space of industrial premises with minimal energy consumption.

One type of automatic control is optimal control used in technical systems to improve efficiency of production processes. An important stage in the development of optimal systems is setting the optimization goal, which mathematically is a requirement to ensure the minimum or maximum of some quality index (optimality criterion) (Hamdi et al., 1999). The quality control criterion for the developed system is maximum comfort with minimum energy consumption.

While designing automatic control systems (ACS), it is necessary to know the transient characteristics of both individual elements and the system as a whole in order to select the controller, sensors, actuators. To study operating modes of the internal air quality control system (IAQCS), a mathematical model was created, the structural scheme of which is shown in Fig. 5.

The model of the internal air quality control system consists of separate units: a fuzzy expert control system, electric drive models (frequency converters, asynchronous motors, a fan and a pump), room models, aerodynamic and pressure characteristics, a voltage regulator, an ultrasonic air ion generator and quality control criterion model.

The control algorithms are implemented with a fuzzy logic mathematical apparatus, where expert knowledge and prioritizable dependencies instead of differential equations are used to describe the system.

The electric motor model has a three-phase AM and frequency converter FK. In calculations, the asynchronous machine includes the model of the electrical part and the mechanical part.

Main energy characteristics of the FK-AM system are active power P and efficiency coefficient η . Therefore, the modeling structure includes calculation of energy parameters.

Calculation of the VR models and the ultrasonic air ion generator is carried out according to standard methods.

In calculation units for aerodynamic characteristics and head and rate specifications, functional dependencies between the parameters of fan aerodynamic characteristics and head and rate specifications of the pump are used.

The main element of the system is the fuzzy expert control system, which, depending on the operating mode, addi-

tional settings and parameters of the premises microclimate (temperature, humidity, air ion concentration), optimized by the combined criterion, carries out joint control of the ventilation unit, the pump unit, the drive and the ultrasonic air ion generator by the voltage regulator (Fig. 5). The fuzzy system for creating and maintaining the internal air quality consists of three fuzzy regulators. The first one is used to control the fan speed, the second one controls the pump speed, the third one controls the power of the ultrasonic air ion generator.

The task of the fuzzy controller in the system under study is to provide maximum efficiency and maximum comfort conditions with minimum power consumption.

This method is to use the data obtained when determining optimal parameters of the airspace of industrial premises (Zaporozhets et al., 2017). However, creation of these optimal values of negative air ion concentration (4000 cm^{-3}) in the working zone using the developed ionizer is rather problematic, so we determine these indicators by 50–100% above the normalized ones ($600\text{--}700 \text{ cm}^{-3}$).

In accordance with this method, the following quality (optimality) criterion of the internal air quality control system was formulated:

$$\left\{ \begin{aligned} I_k &= \left(\frac{T_z - T_i}{T_z} \right) + \alpha_1 \left(\frac{\varphi_z - \varphi_i}{\varphi_z} \right) + \alpha_2 \left(\frac{n_z^- - n_i^-}{n_z^-} \right) \rightarrow \min \\ \varphi_z < 35, \% & \quad T_z \in [21; 22], \text{ }^\circ\text{C} \quad n^- \in [1300; 1500], \text{ cm}^{-3} \\ \varphi_z \in [35; 45], \% & \quad T_z \in [22; 34], \text{ }^\circ\text{C} \quad n^- \in [1100; 1300], \text{ cm}^{-3} \\ \varphi_z > 45, \% & \quad T_z \in [18; 20], \text{ }^\circ\text{C} \quad n^- \in [900; 1100], \text{ cm}^{-3} \end{aligned} \right. \quad (3)$$

where T_z , T_i are predetermined and current values of the temperature in the room; φ_z , φ_i (ϕ) are predetermined and current humidity values; n_z^- , n_i^- are predetermined and current values of air ion concentration; α_1 , α_2 (α) are weight coefficients.

Values of the proposed system control criterion must be inversely proportional to the value of the previously introduced comfort factor (Sukach, 2014).

The criterion is developed independently in accordance with the sanitary and hygienic norms of the microclimate of industrial premises, parameters PMV (Predicted Mean Voice), which determine comfort of the environment for people by the size of discomfort indices D_n (DSTU B EN ISO 7730:2011, 2012) and the obtained parameters of optimal comfort in the working zone of the premises according to atmosphere indicators. The expression is analytic. The relative values of the microclimate parameters are squared (the function is differentiated at each of its points) and added together. The condition of maximum air quality is the minimum criterion.

Discussion

To confirm the veracity and reliability of implementation of the developed system and its influence on greenhouse crop yields, it is necessary to conduct research on the following priority areas:

- to establish patterns of mutual influence of physical and chemical parameters of greenhouse microclimate on efficiency indices of plant cultivation;
- to carry out experiments in real conditions of artificial closed ecosystems of the internal air quality control system with the proposed quality criterion;
- to collect statistical data and to design prediction models of the dynamics of greenhouse microclimate parameters, taking into account destabilizing or limiting factors.

Conclusions

1. The paper proposed an approach to a possible mechanism for creating air ions and hydro air ions in greenhouse premises in the presence of chemical substances, which is the result of biochemical processes in soils, under the action of ultrasound.

2. Application of the developed small-sized ultrasonic air ion generator not only significantly increases air ion concentration in the working zone, but also due to the baloelectric effect minimizes negative effects which most of the existing ionizers have, namely, generation of ozone and nitrogen oxide. That greatly improves the quality of internal air and thereby increases the level of industrial and occupational safety.

3. We proposed the structure of the intelligent internal air quality control system, which changes fan speed and pump speed and the power of the ultrasonic air ion generator.

4. For the first time, we proposed the formalized optimality criterion for the internal air quality control system, which depends on individual preferences of people regarding comfort of the environment and the standardized parameters of

temperature, relative humidity and concentration of air ions in the working zone. The task of the intelligent control system is to minimize the proposed criterion.

References

- Belyaev, N. N., & Tsygankova, S. G.** (2015). Evaluation of the air ions regime in work area at artificial indoor air ionization. *Scientific Bulletin construction KNUCEA*, 3(81), 158-161 (Ru).
- Chizhevsky, A. L.** (1999). *Air Ions and Life*. M.: Mysl, 716 pp. (Ru).
- DSTU B EN ISO 7730:2011** (2012). Ergonomics of thermal environment. Analytical definition and interpretation of thermal comfort on the basis of calculations of PMV and PPD indices and criteria of local thermal comfort. *Minrehion Ukrainy*, 60 pp. (Ukr).
- Dyment, P.** (2014). Clean indoor air for health and sustainability. *REHVA journal*, (5), 59-60.
- Fanger, P. O.** (2003). Quality of indoor air in the twenty-first century: the impact on comfort, productivity and people's health. *AVOK*, 4, 12-22 (Ru)
- Hamdi, M., Lachiver, G., & Michaud, F.** (1999). A new predictive thermal sensation index of human response. *Energy and Buildings*, 29(2), 167-178.
- Skipetrov, V. P.** (2005). *Air Ions and Life*, 3rd ed., rev. "Kras. Okt.", Saransk, 136 pp. (Ru)
- Sukach, S. V.** (2014). Multivariable mathematical model of comfortable air environment of classrooms. *Transactions of the Kremenchuk Mykhailo Ostrohradskyi National University*, 5(88), 112-117 (Ukr).
- Sukach, S. V., & Zaporozhets, O. I.** (2014). Innovative approaches to automation and control of ventilation systems functioning. *Management of Development of Difficult Systems*, 20, 185-190 (Ukr).
- Sukach, S. V.** (2015). Investigation of the influence of ventilation systems on air ionic composition of air in non-standard rooms. *NNDIPBOP. Problems of Labor Protection in Ukraine*, 30, 58-66 (Ukr).
- Zaporozhets, O., Sukach, S., Galagan, O. & Kozlovskaya, T.** (2017). Determination of the parameters optimum comfort in the working area facilities in air environment indicators. *Transactions of the Kremenchuk Mykhailo Ostrohradskyi National University*, 1(102), 17-21 (Ukr).